



WORKSHOP SERIES

**PORTABLE COMPRESSOR FOR GENERAL
LIGHT DUTY TASK AROUND THE HOME**



MODEL NO. RA2021

Read this material before using this product.
Failure to do so can result in injury.
SAVE THIS MANUAL

www.remingtonair.co.nz



TECHNICAL INFORMATION

Specifications	
Air Compressor	RA2021
Voltage	240V AC ~ 50Hz
Motor	Electric 2 Hp
Wattage	1500W
No Load Speed	2800 RPM
Free Air Delivery (FAD)	95 L per minute*
Tank Size	21 L

SUGGESTED APPLICATIONS

You may use some light duty air tools with this compressor. Some examples of light duty tools are:

- Ball Inflator
- Toy Inflator
- Tyre Inflator
- Mini Air Brush
- Touch Up Spray Gun
- Stapler
- Combo Nailer
- C-Bradder
- T-Nailer

This light duty air compressor is NOT recommended for use with a full spray gun.

CONTENTS

Section	Page
Contents	2
Suggested Applications	2
Introduction	3
General Safety Instructions	4 – 6
Electrical Information	7
Specific Safety Instructions	7
Components and Controls	8
Operating Instructions	9 – 15
Maintenance	16
Trouble Shooting	16
Parts Diagram	17
WARRANTY	18



INTRODUCTION

Dear Customer,

Thank you for purchasing this compressor which has passed through our extensive quality assurance processes. Every care has been taken to ensure that it reaches you in perfect condition. However, in the unlikely event that you should experience a problem, or if you require any assistance please do not hesitate to contact us;

LUBRICATION OF COMPRESSOR

Before attempting to operate this air compressor the transport plug must be removed, thrown out and replaced with the oil breather. Check the oil level to ensure the level is to the top of the red dot on the sight glass; refer to page 10 for complete details and diagram. Failure to do this may result in damage to the air compressor and / or injury to the user.

PLEASE follow the instructions noted on page 10 on replacing the transport plug to the oil breather.

ASSEMBLY

This compressor **MUST** be fully assembled by you prior to use. Failure to do so will result in the warranty being VOID. Failure to fully assemble this compressor may also result in personal injury.

SAFETY

Before attempting to operate this air compressor the following basic safety precautions should be taken to reduce the risk of fire, electric shock and personal injury. It is important to read the instruction manual and to understand applications, limitations and potential hazards associated with the air compressor. This air compressor is not intended for use by persons (including children) with reduced physical, sensory or mental capabilities, or lack of experience and knowledge, unless they have been given supervision or instruction concerning the use of the appliance by a person responsible for their safety.

BEWARE OF CHILDREN AND PETS

Children and pets should be kept out of the work area. Children should not be allowed to touch or operate the air compressor, tools or extension cords. This air compressor is not designed for use by young children or infirm persons without supervision. The air compressor and tools should be kept out of reach of children, preferably stored or locked in a secure cabinet or room when not in use.

WORK AREA

Work areas and benches should be kept tidy. Cluttered benches and work areas can cause accidents. Floors should be kept clean and free from rubbish. Special care should be taken when the floor is slippery due to sawdust or wax. Always leave sufficient distance, at least 5 metres between the air compressor and the work area, especially when using tools designed for sanding or spraying liquids.

WORK ENVIRONMENT

Do not expose your air compressor to rain or use in damp or wet conditions. Keep the work area well lit. Always ensure your compressor is level and stable. Using your compressor on unlevel or unstable ground may cause a lack of lubrication and the pump to seize, this damage will not be covered under warranty.

GUARD AGAINST ELECTRIC SHOCK

Avoid body contact with earthed or grounded surfaces (e.g. pipes and refrigerators).

DO NOT FORCE AIR COMPRESSORS

The air compressor will do a better, safer job and give you much better service if it's used at the duty cycle for which it was designed. The duty cycle will only take effect after the initial (1st) tank fill for the day. This air compressors duty cycle is 75%. Duty cycle is the proportion of time during which the air compressor is operated. This means after 45 seconds of operation, motor pumping, the air compressor must be left for 15 seconds resting, motor not pumping. When the motor is pumping the attached air tool can not be used. Simple way to understand duty cycle is only use the attached air tool while the compressor is not pumping. Stop using the attached tool as soon as the air compressor starts pumping.

USE THE RIGHT TOOL

Select the right tool for the job. Do not use a tool for a job for which it was not designed. Do not force a small air compressor to do the job of a heavy-duty air compressor. Do not use the air compressor for purposes not intended.



DO NOT ABUSE THE POWER CORD

Never yank or pull on the power cord to disconnect it from the mains supply socket. Never carry or pull your air compressor by its power cord. Keep the power cord away from heat, oil, solvents and sharp edges. If the power cord becomes damaged have it replaced by an authorised service facility.

EXTENSION CORDS AND REELS

This air compressor **MUST** be plugged directly into a 230V AC wall socket.

This air compressor is **NOT** designed to be run off an extension cord/lead. If you need extra distance do **NOT** use an extension cord, **USE A LONGER AIR HOSE**.

The use of extension cords may cause power voltage loss and will result in damage to the motor. This will **NOT** be covered under warranty.

SECURE THE WORK PIECE

Whenever possible secure the work piece using clamps or a vice. It is safer than using your hands or feet and leaves both hands free to control the tool.

HOT COMPONENTS

Beware many of the components will get hot during use. Never touch any of the metal pipes, pump or motor as these may burn.

MAINTAIN YOUR AIR COMPRESSOR WITH CARE

Follow the instructions for lubricating and changing accessories. Check the air compressor power cord periodically and if damaged have it replaced by an authorised service facility. Keep handles clean, dry and free from oil and grease. Ensure that ventilation slots are kept clean and free from dust at all times. Blocked ventilation slots can cause overheating and damage to the motor.

DISCONNECT AIR COMPRESSOR

Ensure that the air compressor is disconnected from the mains supply when not in use, before servicing, lubricating, making adjustments or when changing any accessories.

REMOVE ADJUSTING KEYS AND WRENCHES

Form the habit of always checking to see that any adjusting keys or wrenches have been removed from the air compressor before operating.

AVOID UNINTENTIONAL STARTING

Ensure that the switch is in the 'OFF' position before plugging the air compressor into the mains supply.

PROTECT FURNISHINGS

If using the air compressor inside your house, protect furnishings and floors with a suitable dust sheet.

FIRE PRECAUTIONS

When using the air compressor inside your house or workshop general fire precautions should be observed. As a precaution it is recommended that an expert is consulted on obtaining and using a suitable fire extinguisher.

CLEANING YOUR AIR COMPRESSOR

Always disconnect your air compressor from the mains power supply before you commence cleaning. Always ensure that your air compressor has cooled, about one (1) hour, before cleaning and storing. When cleaning your air compressor use only a damp soft cloth. **NEVER** use liquid or solvents of any type. standards and safety requirements. Repairs should only be carried out by qualified persons using original spare parts. Failure to do so may result in considerable danger to the operator.

CHECK DAMAGED PARTS

Before using the air compressor it should be carefully checked to determine that it will operate properly and perform its intended function.

Check for the correct alignment of moving parts ensuring that they do not bind. Check for broken or missing parts and have them replaced or repaired at an authorised service facility. Check any other condition that may affect the operation of the air compressor. A guard or any other part of the air compressor that is damaged should be properly repaired or replaced by an authorised service facility unless otherwise indicated in this instruction manual.

Any switch that does not operate correctly must be replaced by an authorised service facility.

DO NOT use the air compressor if the RED 'ON / OFF' button does not turn the air compressor 'ON' and 'OFF'.

DO NOT use the power point switch to operate the air compressor as this will cause damage and injury may occur. Any damage will not be covered under warranty.

PERSONAL SAFETY

Clothing

Do not wear loose clothing, jewelry or anything that could get caught in moving machinery.

Hair

Long hair should be tied back or contained in a protective covering.

Eye Protection

The use of safety goggles is highly recommended (normal glasses are not sufficient for eye protection) when using an air compressor. Prescription glasses do not have safety lenses.

Footwear

Where there is the risk of heavy objects or if there is a risk of slipping on wet or slippery floors, suitable non-slip safety footwear should be worn. Protect your feet from dropping accidents.

Ear Protection

The use of ear protection is highly recommended when using air compressors. The continual noise may damage your ears.

Respiratory Protection

When operating any machinery that creates dust or when spray painting, an approved dust / filter mask must be worn. When machining concrete, man made fibres, especially MDF (Medium Density Fibre board), the resin used in these materials can be hazardous to your health. Use an approved face mask with replaceable filter.

Do Not Over Reach

Do not over reach. Keep a proper footing and maintain your balance at all times. Avoid using abnormal stances and awkward body positions.

Stay Alert

Watch what you are doing, use common sense, and never operate an air compressor when you are tired, drinking alcohol, taking drugs or if taking medication that causes drowsiness.

WARNING

Only use compressor with oil breather fitted.

Only use compressor when fully assembled

Do not attempt to modify the air compressor in any way; this will VOID your warranty.

The use of any attachment or accessory other than those recommended in this instruction manual could result in damage to the air compressor and could cause injuries to the operator.

This electric air compressor complies with Australian / New Zealand and International standards and safety requirements. Repairs should only be carried out by qualified persons using original spare parts. Failure to do so may result in considerable danger to the operator.

ELECTRICAL DATA



IMPORTANT

This air compressor is fitted with a sealed electrical connection plug that is compatible with the mains power supply for Australia / New Zealand and meets the requirements of international standards. This air compressor must be connected to a supply voltage that is equal to that stated on the rating label. If the mains power connection plug or power cord becomes damaged it must be replaced with a complete assembly that is identical to the original, and this must be replaced by an authorised service centre. Always follow the Australian / New Zealand requirements for connection to the mains supply. If in doubt always consult a qualified electrician.

SPECIFIC SAFETY INSTRUCTIONS

Warning! Do not use the air compressor in areas where there is a risk of explosion or fire from combustible materials. The sparks generated from certain tools attached to air compressor can ignite combustible materials as well as flammable liquids, paint, varnish, petrol, flammable gases and dust of an explosive nature. As a precaution it is recommended that you consult an expert on a suitable fire extinguisher and its use.

- **Initially remove the transport plug and replace with the oil breather BEFORE using the first time, see page 10.**
- **Do not attempt to modify the air compressor, guards or the supplied accessories in any way.**
- **Domestic air compressors are designed for intermittent operation. Ideally a 75% duty cycle. (Meaning. 45 seconds ON motor pumping and 15 seconds OFF, motor not pumping). Simply put when the motor is pumping the attached air tool can not be used. Only use the attached air tool while the compressor is not pumping.**
- **Stop using the attached tool as soon as the air compressor starts pumping.**
- **Always check the oil level before use. Oil level should be above the red dot on the sight glass.**
- **Fully assemble compressor before use.**
- **Always ensure your compressor is level and stable. Using your compressor on unlevel or unstable ground may cause a lack of lubrication and the pump to seize, this damage will not be covered under warranty.**
- **Never run this compressor with the wheels and rubber stopper being correctly fitted.**
- **Never use an extension cord with this compressor always use a longer air hose.**
- **Never connect to a generator which does not produce sufficient power, at least 3000W and has pure sine wave power output.**

- Domestic air compressors are not designed for industrial / commercial applications.
- Domestic air compressors are not designed for continuous running.
- Avoid touching the pump area as it can become very hot and may burn.
- Ensure that the air compressor is disconnected from the mains supply when not in use, before servicing, lubricating, making changes and when changing attachments such as air hoses / tools.
- Always use the correct type of tool for the operation to be carried out.
- Never use the air compressor if any part of the unit is damaged. Always have the air compressor serviced by an authorised service agent.
- Always wear safety eye, ear and respiratory protection when operating the air compressor.
- Allow the tank to completely fill before using the air compressor.
- If the air compressor makes an unfamiliar sound or vibrates excessively, switch the air compressor 'OFF' immediately and disconnect from the mains power supply. Investigate the possible cause or consult your authorised service facility.
- Always move the air compressor using the handle and wheels.
- Always use the air compressor on stable ground.
- This air compressor is designed to compress normal air. Never use to compress any other type (s) of gases.
- Never direct the jet of air or other liquids / gases towards your body, other persons or animals.
- Never direct the jet of air or other liquids / gases towards this air compressor.
- This air compressor is not suitable for pharmaceutical, food or sanitary purposes.
- This air compressor is not to be used to fill scuba or oxygen air bottles or tanks.
- Always follow the instructions relating to the tools attached to this air compressor

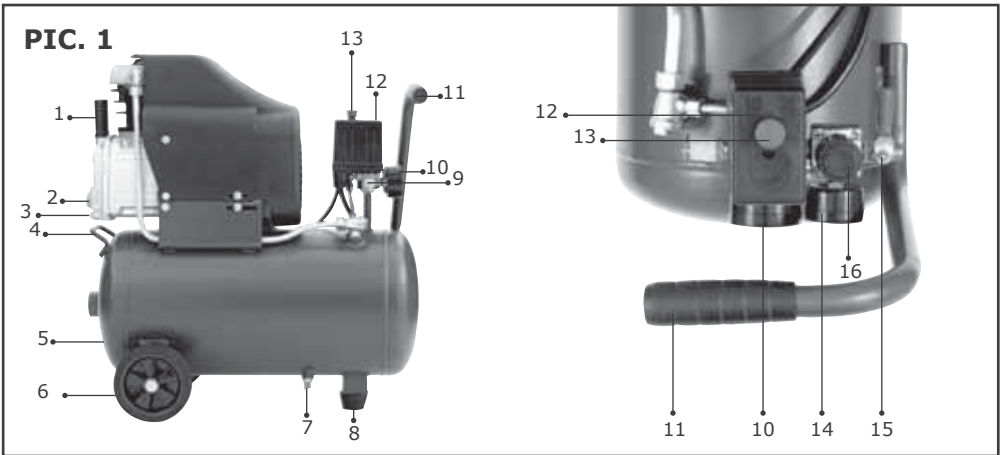

COMPONENTS AND CONTROLS

Pic. 1

- 1.Oil fill and breather
- 2. Oil sight glass
- 3. Oil drain bolt
- 4. Rear handle
- 5. Tank
- 6. Wheels
- 7. Tank drain tap
- 8. Rubber stopper
- 9. Safety Valve
- 10. Tank pressure gauge - large
- 11. Front handle
- 12. Pressure switch
- 13. On / Off button – red colour
- 14. Outlet pressure gauge - small
- 15. Air tap – Air outlet
- 16. Outlet pressure regulator
- 17. Air filter – metal (Not shown)
- 18. Transport Plug (Not shown)

OPERATING INSTRUCTIONS

Unpacking

Carefully unpack your air compressor. This air compressor is bulky and heavy, two (2) person lift required. Dispose of all packing material in an environmentally responsible manner.

Assembly

Your air compressor requires minor assembly before initial operation. Check that you have all components required for assembly and initial use.

Your compressor is filled with oil do not tip to assemble.

Oil Breather

To fit the oil breather:

1. Remove the transport plug and throw away, see Pic. 2.
2. Screw in the oil breather, see Pic. 2.

Lubrication

Warning: Your air compressor IS FILLED with OIL!

To check the oil level;

1. Always check the oil level when the air compressor is on flat and level ground.
2. To confirm the oil level lift the back, wheel end, up about 20cm, hold for about 1 minute and place back on ground.

Look at the sight glass and ensure the oil is above the red dot on the sight glass, as per the "OIL LEVEL GAUGE" label, see Pic. 3 and Pic. 4.

To add oil, if required, additional oil not included;

1. Remove oil breather.
2. Add oil, SAE30 to at least the top of the red dot, see Pic. 4.
3. Oil level will take about 1 minute to drain down and settle.
4. Check oil level in sight glass, see Pic. 3, Re-check and top up if required, until level is correct.

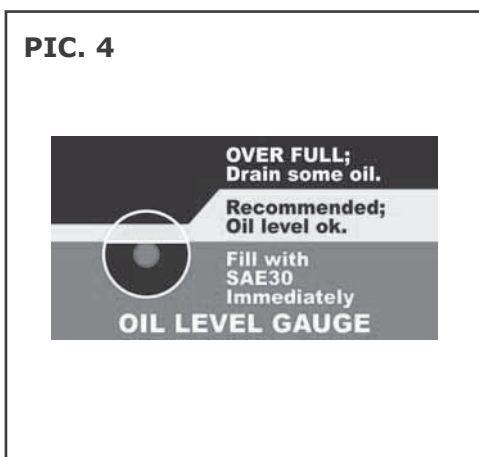
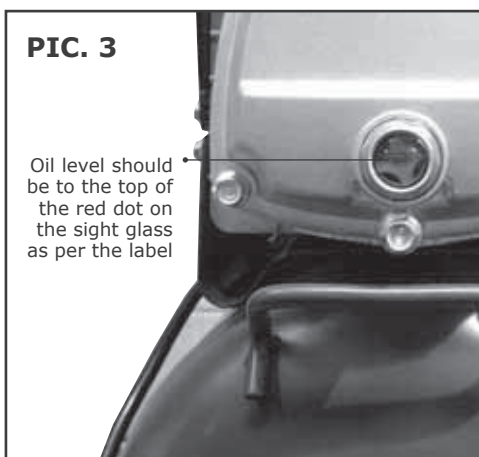
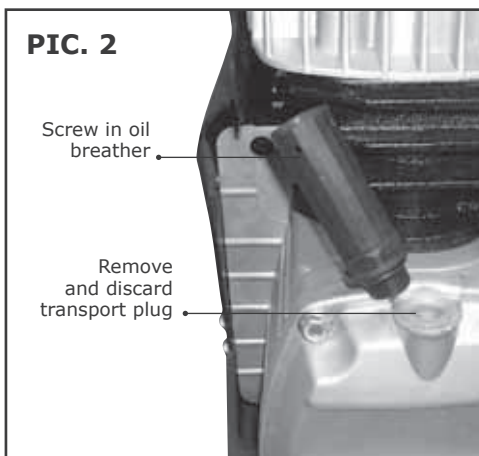

WARNING

Do not attempt to operate this compressor until it is fully assembled.

Damage caused due to incomplete assembly will not be covered under warranty.

Ensure the air compressor is disconnected from the power supply before carrying out any assembly, maintenance or adjustments on the machine.

Never under fill or over fill with oil.

RUBBER STOPPER

To attach the rubber stoppers to the bracket located on the bottom of the tank;

1. Undo the nut and remove the washer.
2. Push through the bracket and replace the washer.
3. Tighten the nut, Pic. 5

PIC. 5



WHEELS

1. Insert a bolt through the wheel.
2. Push through the tank wheel bracket.
3. Tighten the nut, Pic. 6.

PIC. 6

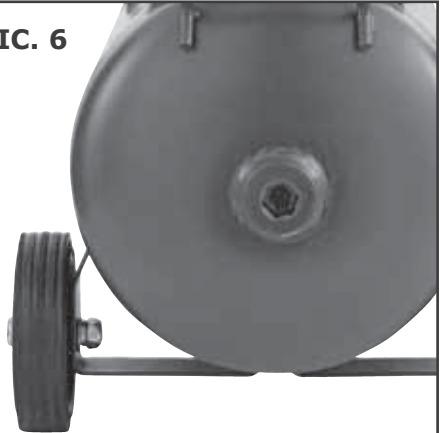

AIR FILTER

The supplied air filter must be used.

Failure to do so may result in irreparable damage and will void the warranty, Pic. 7

To install;

1. Carefully screw supplied air filter into the threaded hole on the top of the pump head. This only needs to be done up by hand. Do not use tools to tighten air filter.

NOTE: Do not OVER TIGHTEN as this may damage the air filter or cylinder head which will NOT be covered under warranty.

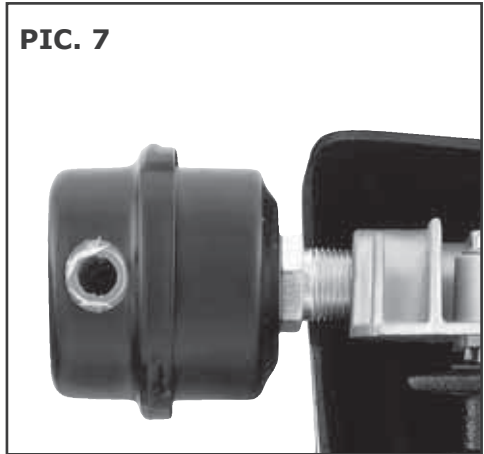

STARTING AND STOPPING YOUR AIR COMPRESSOR

Pic. 8

NOTE: Always ensure that you plug your air compressor into a standard 230V AC power point. Never use an extension cord as this can lead to a voltage drop which may cause power loss and over heating. Use a longer air hose if you need to get closer to your work area.

Always start and stop the compressor using the ON/OFF button on the Pressure Switch (Pic. 1 Item 12 and 13 as well as Pic. 8). Never use the power point switch to operate the compressor as this will cause damage and injury may occur. Damage caused by not using this button will not be covered by warranty.

To turn your air compressor ON;

Lift up the red ON / OFF button on top of the pressure switch

To turn your air compressor OFF;

Push down the red ON / OFF button on top of the pressure switch

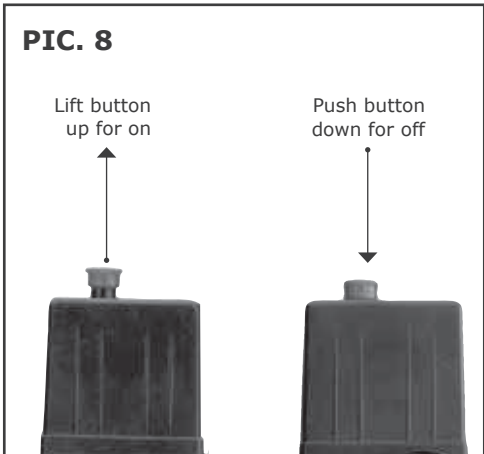

RUNNING IN YOUR NEW AIR COMPRESSOR

Before running in ensure that the following has been completed;

1. The transport plug has been removed and discarded, see pic. 2 page 10.
2. The oil breather has been fitted, see page 10.
3. Oil level is correct, see pic. 4 page 10.
4. The air compressor has been fully assembled, see pages 10 – 12.

Your new air compressor requires running in:

1. Plug the power cord into a standard 230V AC power point
2. Open the air tap
3. Open the tank drain tap
4. Start the air compressor using the ON / OFF button
5. Run the air compressor for approximately 1 minutes

This ensures that the air compressor is fully lubricated under no load.

After the 1 minute stop the air compressor using the ON / OFF button. Allow to cool approximately 10 minutes. Recheck the oil level and top up if needed, additional oil, SAE30, not included.

Before starting your air compressor again ensure;

1. Air tap is closed
2. Tank drain tap is closed

USING THE AIR COMPRESSOR

Before starting run through this simple list;

1. Transport plug removed and discarded, see Pic. 2, page 10.
2. Oil breather fitted, see Pic. 2, page 10.
3. Oil level – CORRECT (top of red dot). Please refer to diagram, Pic. 4, page 10.
4. Air tap – CLOSED
5. Drain tap – open and drain tank
6. Drain tap – close fully
7. Check power lead for any damage. If damaged have replaced by an authorised service centre.
8. Plug air compressor into a standard 240V 10Amp AC power point and turn ON.
9. Lift the air compressor button to turn ON, see page 12, Pic.8.
10. Allow the air compressor to fill the air tank.
11. Turn the air compressor OFF.
12. Turn the power point OFF and disconnect the power lead from the power point.
13. Connect your air hose and air tools.
14. Reconnect to the power lead to the power point and turn ON.
15. Turn your air compressor ON.
16. Once turned on and you begin using the connected air tools the air compressor will start and stop without warning. This is controlled by the pressure switch. These pressure settings are factory set and should not be changed.

Pumping starts at (minimum) 85PSI and stops at (maximum) 115PSI. Once the initial pump up stage has finished you can adjust the outlet air pressure to the tools recommended working pressure and open the air tap fully.

PIC. 9



The configuration of tools and accessories can be varied to suit your particular requirements. A basic recommended set up is shown in Pic. 9.

When you have finished using your air compressor follow these simple steps;

1. Turn your air compressor OFF, using the ON/OFF switch.
2. Turn the power point OFF and disconnect the power lead.
3. Disconnect your air tools and air hose.
4. Clean your hose and air tools.
5. Store your air hose and air tools in a secure well ventilated cabinet.
6. Slowly open the tank drain tap, see page 16. This allows excess air and moisture, water, to vent.
7. Leave the tank drain tap open. This allows any moisture to drain while the air compressor is stored.

ADJUSTING THE PRESSURE

To adjust the outlet air pressure, use the red coloured regulator knob and check the pressure on the outlet pressure gauge, Pic. 10.

If the pressure needs to be lower, turn anti clockwise. If the pressure needs to be higher, turn clockwise.

Use the gauge to ensure you set the correct working pressure.

Note: Different air tools require different operating pressures. Always check with the tool manufacturer if unsure.

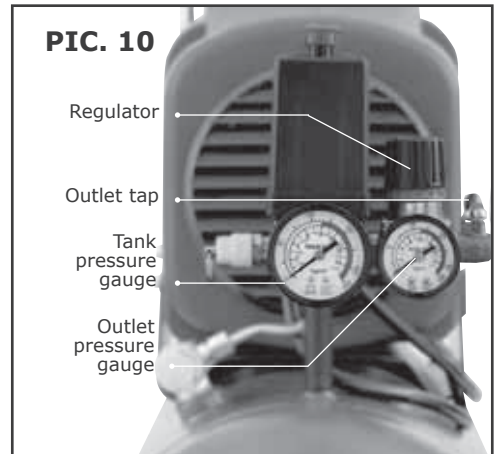

SAFETY VALVE

Pic. 11

NOTE: When checking the safety valve ALWAYS wear safety glasses.

To check the operation of the safety valve the air tank will need to be full. Gently pull the ring outwards. This should release air under pressure. Release the ring and this should stop the air out flow immediately.

If the safety valve does NOT work in this manner, STOP the air compressor immediately and have the air compressor checked / serviced by an authorised service centre.

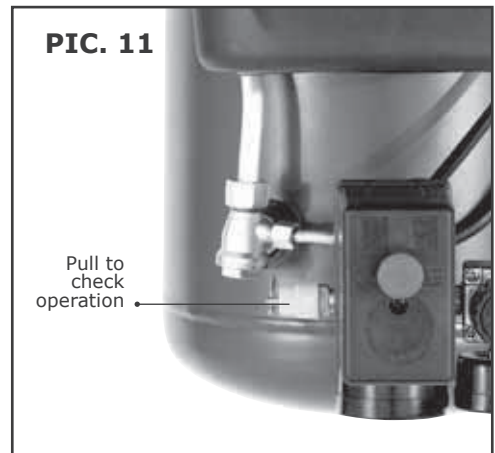

AIR TAP

Pic. 12

The air tap will need to be opened to allow the air to flow to the attached air tool.

To open air tap rotate the handle so that it lines up with the fittings and hose, not supplied.

To close air tap rotate the handle so that it is at 90° to the fittings and hose, not supplied.

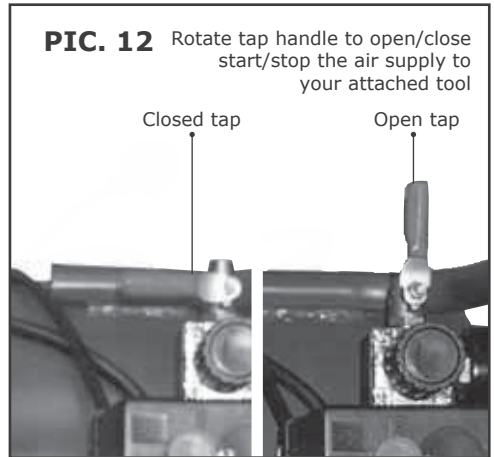

DRAIN TAP

Pic. 13

After use open the drain tap to drain excess air and any moisture. The excess air will also help purge the moisture. Leave the drain tap open when air compressor is not in use, so any moisture can continue to drain

To open the drain tap pull the lever down to vertical.

To seal the drain tap push the lever up to horizontal.

NOTE: Remember to seal the drain tap before starting the compressor.

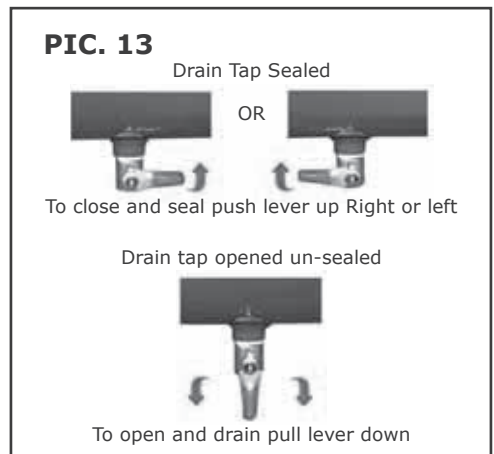

MAINTENANCE

Daily: Before use

1. Seal the tank drain tap, see page 16, Pic.13.
2. Check the oil level, see page 10, Pic. 4.
3. Check safety valve operation, see page 15, Pic.11

After use

1. Open the tank drain tap, see page 16, Pic.13.
2. Wipe down the air compressor.
3. Store safely and securely.

Every 50 Hours:

1. Replace the air filter.
2. Drain oil completely and replace with fresh oil.

To drain;

- a. Loosen and remove the drain bolt, Pic.14 and drain oil into a funnel / bottle and dispose of in an appropriate manner.
- b. Once drained replace and tighten the drain bolt.
- c. Wipe up any oil spills.
- d. Fill up to the top red dot on the sight glass with fresh clean oil. Refer page 10 for "To Add Oil, if Required" details. Refer to diagram Pic. 4, page 10.

NOTE: Use oil type SAE30.

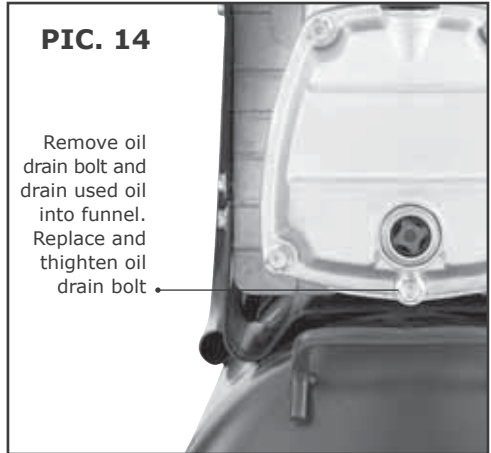

PIC. 14

Remove oil drain bolt and drain used oil into funnel. Replace and tighten oil drain bolt

? TROUBLE SHOOTING

If your compressor does not start

- Check that you have plugged the power lead into a standard 230V 10Amp power point and turned the switch ON.
- Check that you have turned the air compressor ON/OFF switch ON.
- The air tank may be full. Use your air tool and the air compressor should start when the pressure decreases to 85PSI.

If your compressor does not build up pressure

- Check that the tank drain tap is sealed.
- Check that the air tap is closed.

If your compressor smells like burnt oil

- Check the oil level as it may be low

PARTS DIAGRAM

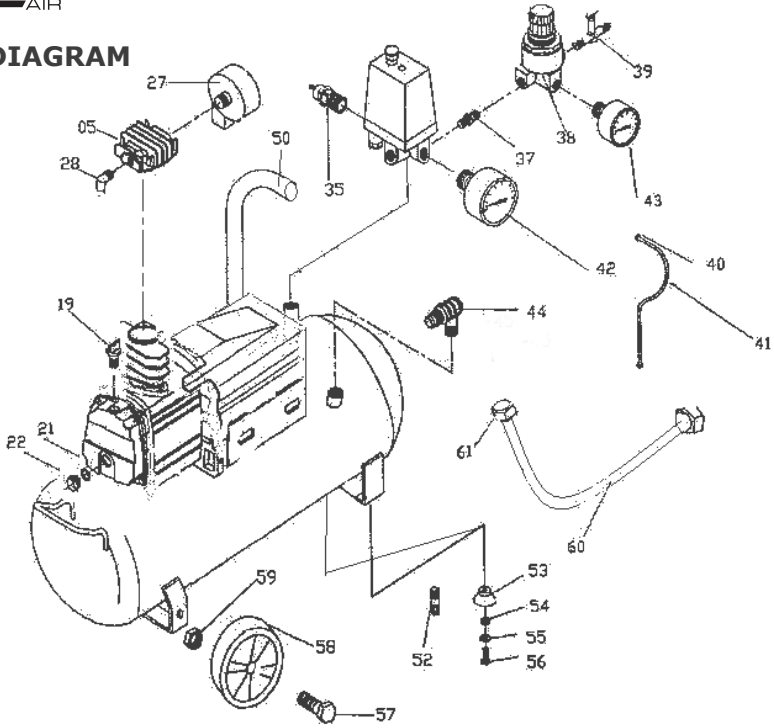

Part	Description	Qty
5	Cylinder Head	1
19	Oil Breather	1
21	Sight Glass Seal	1
22	Sight Glass	1
27	Air Filter	1
28	Exhaust Elbow	1
35	Safety Valve	1
36	Pressure Switch	1
37	Connector	1
38	Regulator Single Tap	1
39	Outlet Tap	2
40	Unloading Tube Nut	2
41	Unloading Tube	1
42	Pressure Gauge Large	1

Part	Description	Qty
43	Pressure Gauge Small	1
44	One Way Valve	1
50	Rubber Handle Grip	1
52	Drain Tap	1
53	Cushion Foot	2
54	Nut	2
55	Washer	2
56	Screw	2
57	Bolt	2
58	Wheel	2
59	Screw Nut	2
60	Exhaust Tube	1
61	Exhaust Tube Nut	2

WARRANTY

As part of an on-going commitment to excellence in product support, Euroquip offers a comprehensive product warranty program.

Registered warranty period for the RA2021

Domestic Use: 12 Months

Warranty covers failure caused by manufacturing and material defects in the product, during the warranty period specified. The warranty period begins when the product is purchased by the end user. Warranty is not transferrable and is only claimable by the original purchaser.

Warranty does not cover parts that are subject to wear and tear from usage.

Warranty covers failure of a product caused by defective materials and/or manufacturing for the period given and the usage specified by Euroquip. The warranty period begins when the product is purchased by the end user. Warranty is not transferrable and is only claimable by the original purchaser.

Warranty also does not cover failure caused by the untimely replacement or service of the above wearing parts. Evidence must be provided that the product has been maintained and serviced suitably for a claim to be considered under warranty.

Failure caused by incorrect operation of the product, lack of proper care and maintenance of the product, external damage, external circumstances such as contaminated fuel or poor water supply, modifications to the product, attempted repair/service by a party other than an Approved Service Agent, is not covered under warranty.

Warranty does not cover pre delivery service and adjustment, or failure that may occur as a result of lack of/ incorrect pre delivery service and adjustment.

Warranty does not cover any incidental, indirect or consequential loss, damage or expense that may result from any defect, failure or malfunction of a product.

Should any issue be found to be a combination of a warranty failure and a non-warranty issue, the repair cost component to rectify and repair the non-warranty failure is the customers' full responsibility.

The decision that an issue with a product qualifies as a warranty claim is made at the sole jurisdiction of Euroquip.

No costs incurred will be considered under warranty if repairs are carried out by a party other than a Euroquip Approved Service Agent, unless with prior consent in writing from Euroquip.

It is the responsibility of the purchaser to deliver a product under warranty to the nearest relevant service agent or product reseller. Warranty does not cover call outs, mileage and freight costs.

If a product is repaired under warranty, parts and labour required for the repair will be supplied at no charge. Warranty assessment and repair will be scheduled and executed according to the normal work flow at the service location and depending on the availability of suitable replacement parts.

This warranty policy is an additional benefit and does not affect the legal rights of any end user, reseller or service agent.





Congratulations on your new REMINGTON AIR product. We are proud to have you as our customer and will strive to provide you with the best service and reliability in the industry. This product is backed by our extensive warranty and service network. To locate your nearest distributor or service agency visit www.euroquip.co.nz or email us at customerservice@euroquip.co.nz.